

Cadre C

Élévation

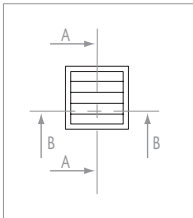

CERTILAM-CERTILUX TS

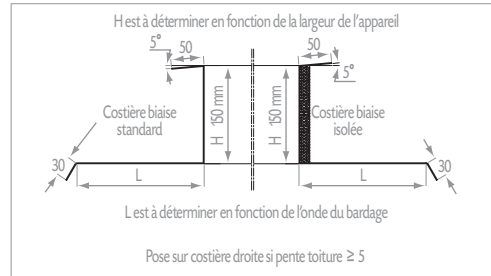

Cadre C

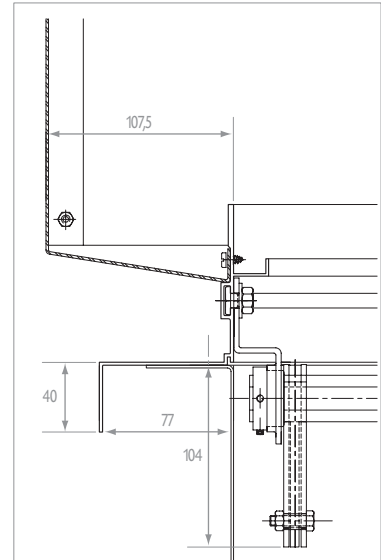

Coupe A-A

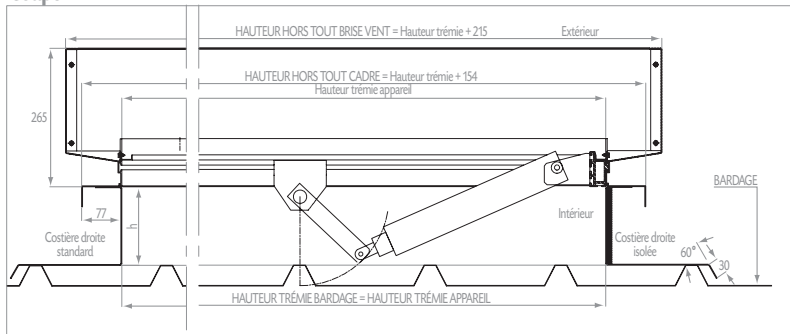

Coupe B-B

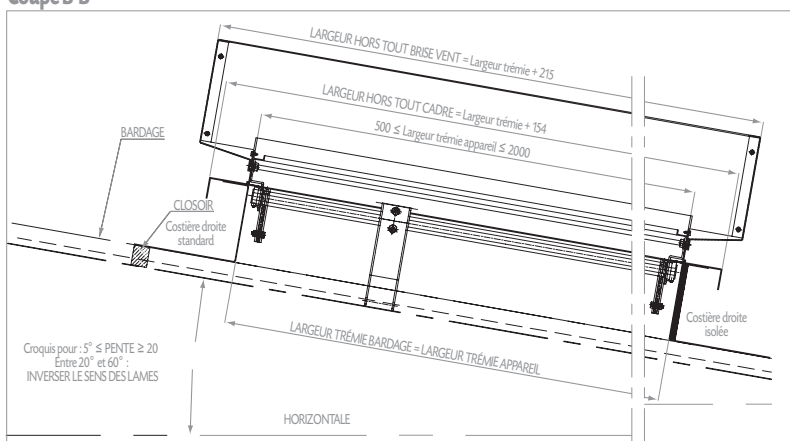

CALCUL HAUTEUR TRÉMIE APPAREIL		Nb de lames
CERTILAM lame standard	(nombre de lames x 125) + 46	6 à 24
CERTILAM lame isolée	(nombre de lames x 125) + 54	6 à 24
CERTILAM lame et cadre isolés	(nombre de lames x 125) + 31	6 à 24
CERTILUX lame verre et polycarbonate 6 mm	(nombre de lames x 160) + 46	6 à 19
CERTILUX lame verre et polycarbonate 10 mm	(nombre de lames x 165) + 48	6 à 19

Cadre F

Les cadres profilés

Élévation

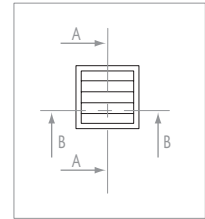

Coupe A-A

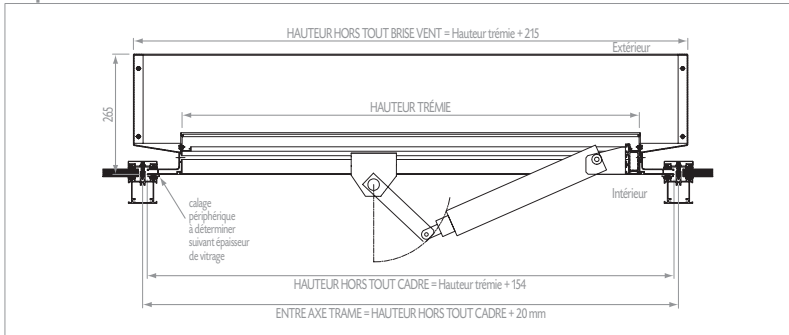

CERTILAM-CERTILUX Cadre F déigné

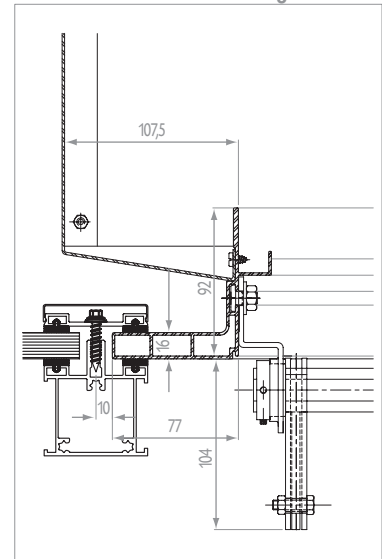

Coupe B-B

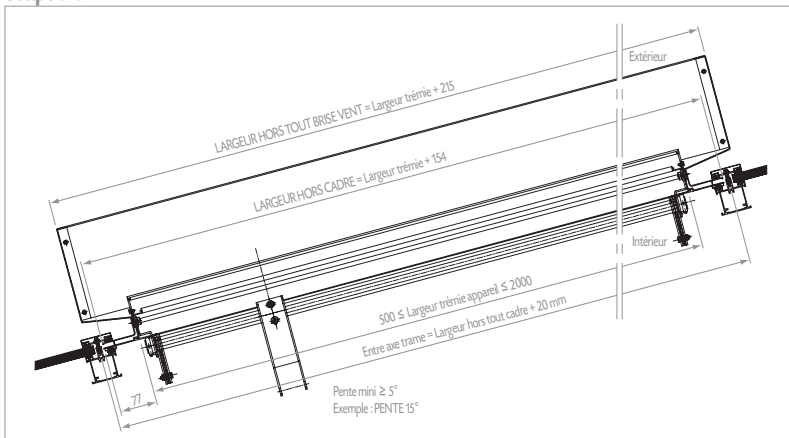

CALCUL HAUTEUR TRÉMIE APPAREIL		Nb de lames
CERTILAM lame standard	(nombre de lames x 125) + 46	6 à 24
CERTILAM lame isolée	(nombre de lames x 125) + 54	6 à 24
CERTILAM lame et cadre isolés	(nombre de lames x 125) + 31	6 à 24
CERTILUX lame verre et polycarbonate 6 mm	(nombre de lames x 160) + 46	6 à 19
CERTILUX lame verre et polycarbonate 10 mm	(nombre de lames x 165) + 48	6 à 19

Cadre G

Élévation

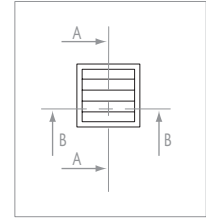

Coupe A-A

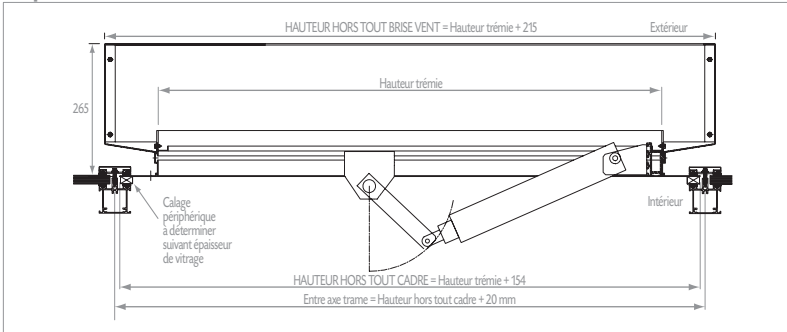

Coupe B-B

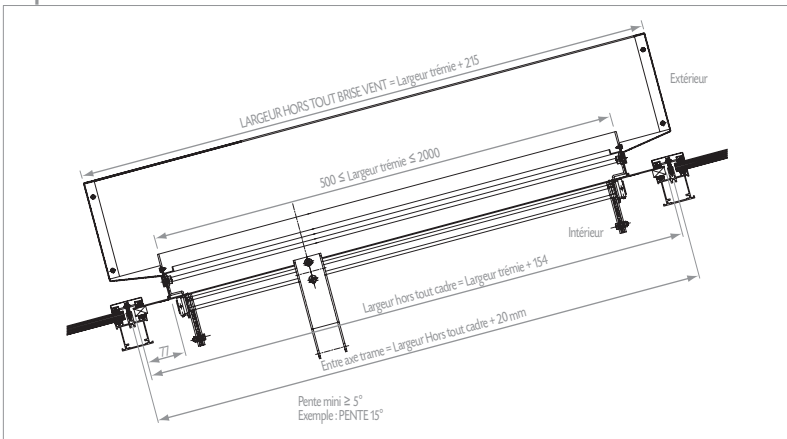

CERTILAM-CERTILUX Cadre G délégué

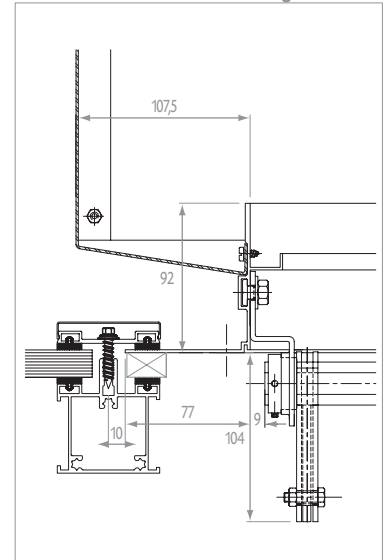

CALCUL HAUTEUR TRÉMIE APPAREIL		Nb de lames
CERTILAM lame standard	(nombre de lames x 125) + 46	6 à 24
CERTILAM lame isolée	(nombre de lames x 125) + 54	6 à 24
CERTILAM lame et cadre isolés	(nombre de lames x 125) + 31	6 à 24
CERTILAM lame verre et polycarbonate 6 mm	(nombre de lames x 160) + 46	6 à 19
CERTILAM lame verre et polycarbonate 10 mm	(nombre de lames x 165) + 48	6 à 19

Cadre J

Les cadres profilés

Élévation

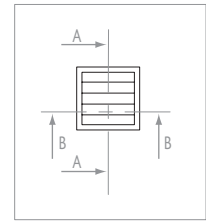

Coupe A-A

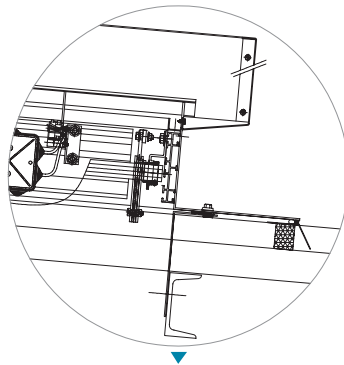
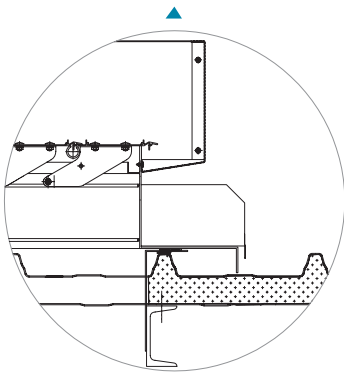
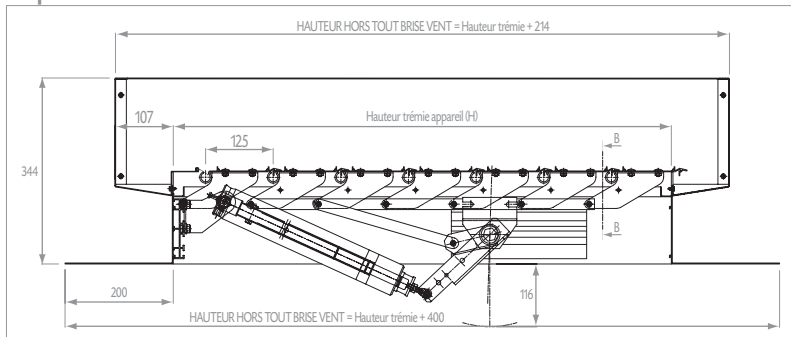

Cadre J

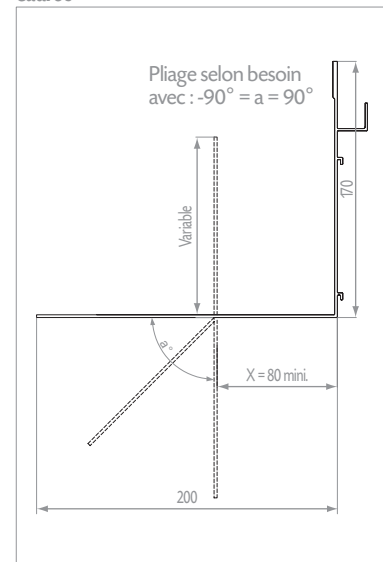

Coupe B-B

